

INFLEX

WITH FLEXUNO



SPECIAL HINGES

PATENTED

OBE
Präzision

INFLEX

WITH FLEXUNO

60-44064

INFLEX – the flex for injected frames

- Only 8 mm long
- Stable mechanism based on flexUno
- Zero rocking thanks to 2 barrels
- Fixation of flex in temple with screw
- Easy gapless construction of temple possible
- Minimum plastic thickness 4.6 mm

Frame application

- Mainly for injected frames
- INFLEX is inserted in temple hole and fixed with screw

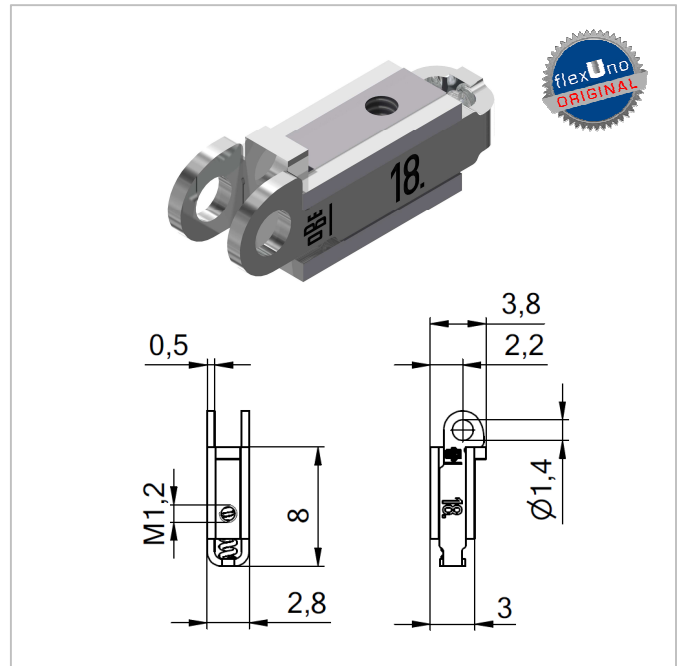

Available versions

- 60-44064.866: loose box with integrated mechanism
- 60-44064.290: already assembled with three barrel block hinge (strong spring) + minus screw
- 60-44064.300: already assembled with one barrel block hinge + pin

Matching parts for 60-44064.866.10

Front hinges for plastic frames 90°	Step hinges for soldering	Hinge screws	Direct joining	Fixation of Inflex with temple
33-04164	52-05265	99-01816 99-02503 99-04816 99-02591 self aligning	99-02907	99-01436 (ø 2.5 with stop) 99-01750 (ø 2.2) 99-02037 (ø 2.2)

Matching parts – Hidden solution

Three barrel block hinges	I	Fixation screws to front	I	Hinge screws
32-04078	I	99-01752 - 3.7mm 99-02023 - 4.4mm 99-02009 - 4.5 mm 99-02028 - 5.6 mm	I	99-01816 99-02503 99-02591 self aligning

INFLEX

WITH FLEXUNO

Available versions:

60-44064.866 + 33-04164

- with 90° front hinge

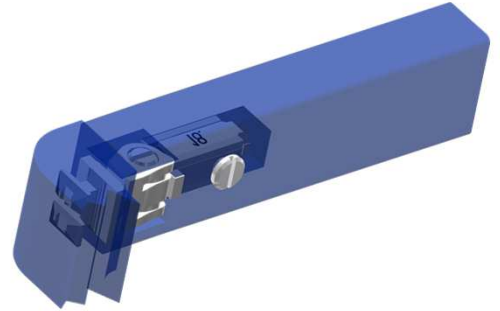

60-44064.866 + 52-05265

- with step hinge

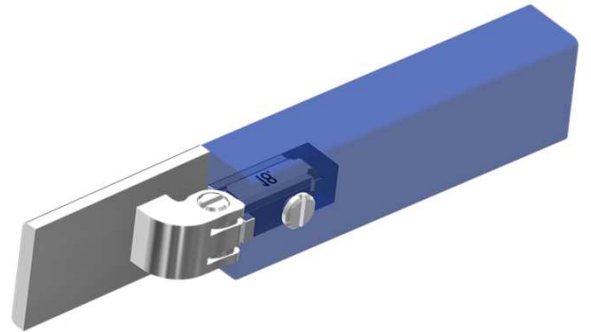

60-44064.866 + 99-02907

- with DJ – Direct joining screw

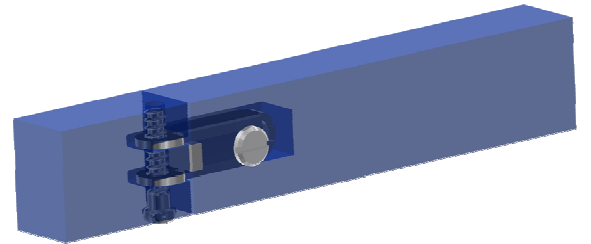

60-44064.290

- assembled with three barrel block hinge

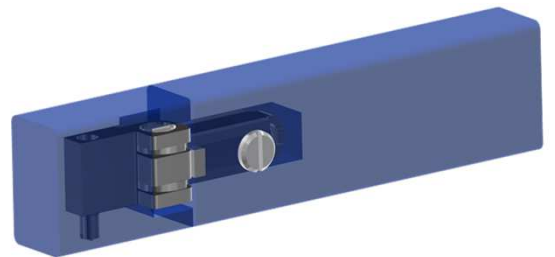

60-44064.300

- assembled with one barrel block hinge

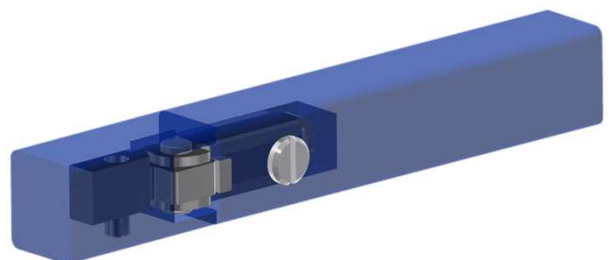



OBE GmbH & Co. KG · Turnstr. 22 · 75228 Ispringen · Germany
Tel. +49 7231 802-0 · www.obe.de · info@obe.de